

*“Save
Your
Breath
With* **NST[®]**
MODERN SAFETY TECHNIQUES

11388 Breininger Rd. * P.O. Box 87 * Hicksville, OH 43526

Phone: (800) 542-6646 * (888) "MOD-SAFE" * (419) 542-6645

Fax: (419) 542-6475 * Email Address: modsafe@bright.net

**SERVICE INSTRUCTIONS
BA050BMST, BA050BNM, BA050BA
BA050BNF-S1, BA050BNM-S1, AND BA050BA-S1
BREATHING AIR PANEL**

NOTE: USE REPLACEMENT CARTRIDGE KIT NO. FB050 FOR ABOVE MODELS

SERVICE INSTRUCTIONS

**WARNING: Always turn off air supply and bleed air pressure before disassembling unit or
SERIOUS INJURY COULD RESULT.**

MST, Inc. recommends replacing all three (3) filter cartridges after one (1) month of use unless conditions warrant more or less frequent replacement. To refill or replace the filter cartridges in the Breathing Air Panel Models BA050B() or BA050B()-S1 follow these steps:

1. PREFILTER FIRST/SECOND DUAL STAGE ELEMENT REPLACEMENT
 - A) First pull Drain Tube (1) up through case, then unscrew Prefilter bowl Assembly (2). Clean in mild soap and water and blow dry with low pressure air.
 - B) Remove Dual Stage Element (3) by unscrewing End Cap Retaining Nut (4).
 - C) Inspect the Prefilter Manifold (5) for dirt/contaminates and clean as required. Inspect "O"-Ring (6) for cuts, etc. and replace if required.
 - D) Install new Dual Stage Element and tighten End Cap Retaining Nut. Be sure Element is seated squarely on Manifold boss and End Cap.
 - E) Apply light film of petroleum jelly on Bowl's beveled edge to provide a good seal between Bowl and "O"-Ring. HAND TIGHTEN ONLY.
 - F) Guide Drain Tube back through hole in case bottom.
 - G) Dispose of used Dual Stage Element according to local, state and federal regulations.

2. THIRD/FOURTH STAGE CARTRIDGE REPLACEMENT
 - A) Loosen Bracket Screw (7) from Bracket (8) .
 - B) Loosen the five Manifold Bolts (9) and remove the front two Bolts. Now slide out the Third (10) and Fourth (11) Stage Aluminum Tube Assemblies.
 - C) Remove the End Cap (12) from Third Stage Aluminum Tube Assembly and slide old Third Stage Filter cartridge (13) out of aluminum tube. Clean aluminum tube in mild soap and water, dry and install new Third Stage filter cartridge. Be sure the Flow Direction Arrow on Third Stage Filter Cartridge is pointing down. Remove End Sealing Label (14) and install new End Cap.
 - D) Follow same procedure for the Fourth Stage Filter Cartridge (15) replacement as in step (C). Be sure the Flow Direction Arrow on Fourth Stage Filter Cartridge is pointing up. Also be sure to remove End Sealing Label before installing new End Cap.
 - E) Now slide the Third and Fourth Stage Aluminum Tube Assemblies back in place and install the front two Manifold Bolts.
 - F) Tighten Manifold Bolts in sequence from center outward to 100 inch-pounds (1.15 Kg-M). Repeat sequence and re-torque bolts to 250 inch-pounds (2.88 kg-M).
 - G) Dispose of used cartridges according to local, state and federal regulations.

3. FINAL CHECK AND CALIBRATION

- A) Pressurize system and check for leaks.
- B) Flush system with compressed air for five (5) minutes.
- C) Calibrate Carbon Monoxide Monitor as outlined in Monitor Manual, if supplied.

MST, Inc. shall not be liable for any injury, loss, or damage, direct or consequential, arising out of the use of or the inability to use this product, beyond the replacement of defective materials or workmanship. Users of supplied air respirators should evaluate their own particular application and perform their own test for air quality to determine the suitability for use of this product.

For further information or questions about service or maintenance care of this unit, contact your local distributor or MST, Inc. (419) 542-6645.

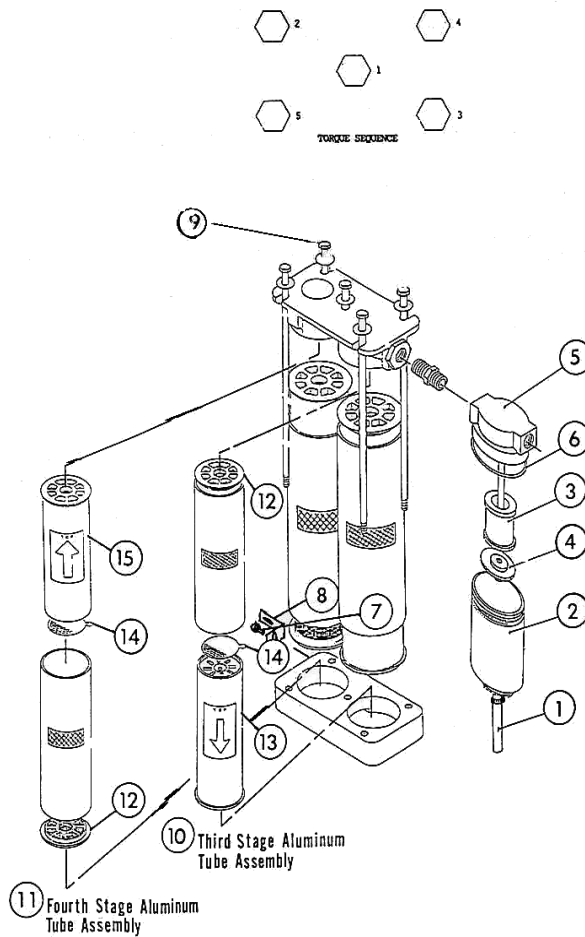

RECEIVED AUG 08 1995

MATERIAL SAFETY DATA SHEET

Page 1 of 6

Revision Date: 2/17/95

Revision No.: 2

1. CHEMICAL PRODUCT AND COMPANY IDENTIFICATION

Product Name: Nuchar WV-B Activated Carbon
Chemical Name: Activated Carbon
Chemical Family: Carbon
Formula: C
CAS Registry Number: 7440-44-0

Manufacturer: **WESTVACO CORPORATION**
Carbon Department
Washington Street
Covington, VA 24426

Telephone Numbers:
Transportation Emergencies:
CHEMTREC (U.S.A.): (800) 424-9300 (24 hours)
CHEMTREC (International): (202) 483-7616 (24 hours, call collect)
Product Information: (703) 962-1121 (EST, 8:00 a.m.-5:00 p.m., M-F)

2. COMPOSITION / INFORMATION ON INGREDIENTS

<u>Components</u>	<u>CAS #</u>	<u>% by Wt.</u>	<u>Hazardous*</u>
Carbon	7440-44-0	> 95	Yes
Phosphoric Acid	7664-38-2	≤ 5	Yes

* By OSHA definition, 29 CFR 1910.1200 (See Section 3 for Hazards Identification, Section 8 for Exposure Guideline, and Section 16 for other information).

3. HAZARDS IDENTIFICATION

EMERGENCY OVERVIEW

This product is an odorless black granular material. Never enter a confined space containing activated carbon since it will adsorb oxygen and asphyxiation may result. Prolonged or repeated exposure to dust may cause eye and respiratory tract irritation.

NUCHAR WV-B ACTIVATED CARBON

Page 2 of 6

Revision Date: 2/17/95Revision No.: 2**3. HAZARDS IDENTIFICATION (Continued)****Potential Health Effects:**

Routes of Entry:	· Inhalation, ingestion, eye and skin contact
Medical Conditions Aggravated by Exposure:	· None documented
Eyes:	· Irritant. Not corrosive
Skin:	· Is not a primary skin irritant, skin sensitizing, or corrosive agent
Ingestion:	· LD ₅₀ (rats) indicates that it is not toxic.
Inhalation:	· Possible irritation of upper respiratory tract
Target Organ Effects:	· Eye irritant
Chronic Effects (Cancer Information):	· NTP: Not listed
	· IARC: Not listed
	· OSHA: Not regulated

4. FIRST AID MEASURES

Eyes:	· Promptly flush eyes with running water for 15 minutes, including water under eyelids. Consult a physician if irritation develops.
Skin:	· Wash affected area well with soap and water. Get medical help if irritation develops.
Ingestion:	· Give 2-3 glasses of milk or water to dilute. Contact physician or poison control center promptly for instructions. If vomiting occurs, give more fluids.
Inhalation:	· Remove to fresh air. Get medical help if irritation develops.

5. FIRE FIGHTING MEASURES

Flammable Properties:	
Hazardous Combustion Products:	· Material will burn in a fire, releasing combustion products of carbon monoxide, carbon dioxide, water, and phosphorus pentoxide.
General Hazards:	· Other materials adsorbed onto the carbon may also be released.
Extinguishing Media:	· Water fog, fire fighting foam, dry chemical, or carbon dioxide
Fire Fighting Instructions:	· Remove all carbon from the building. Fire fighters should wear full protective gear and use self-contained breathing apparatus with a full facepiece. (MSHA/NIOSH approved or equivalent)
Other Information:	
Flashpoint:	· Not applicable
ASTM Ignition Temperature, D4366:	· 420-450°C
Flammability Limits in Air (% by volume):	· LFL: Not applicable
	· UFL: Not applicable

NUCHAR WV-B ACTIVATED CARBON

6. ACCIDENTAL RELEASE (SPILL MEASURES)

- Notify safety personnel for large spills. Avoid generation of airborne dust. Scoop up solid for recovery or disposal. Those involved in clean-up need protection against skin and eye contact and inhalation of dust or mist.

7. HANDLING AND STORAGE

- Handling:
- Follow good handling and housekeeping procedures, avoiding spills, accumulation of dust, and generation of airborne dust.
 - Avoid prolonged contact with skin and eyes.
 - Avoid inhalation of dust.
 - Wear rubber gloves and safety glasses or goggles.
 - Use with adequate ventilation.
 - Wash thoroughly after handling.
- Storage:
- Store in a sealed container in a clean, dry, well-ventilated area away from strong oxidizers, ignition sources, combustible materials, and heat.

8. EXPOSURE CONTROLS / PERSONAL PROTECTION

- Engineering Controls:
- Use general and local exhaust ventilation for nuisance dust and to prevent irritating concentrations of dust or mist in the workplace. Ventilation requirements will depend on the process and should be adequate to avoid exceeding the recommended TLV's.
- Eye Protection:
- Wear safety glasses with side shields, safety goggles, or a face shield, especially in dusty conditions. Provide an eye wash station nearby.
- Skin Protection:
- Wear work or disposable gloves and long sleeve shirts to prevent long term exposure.
- Respiratory Protection:
- Wear a NIOSH approved dust mask to limit exposure. An approved self-contained breathing apparatus with full facepiece is recommended for nonroutine or emergency conditions for inhalation protection.
- Other Protective Equipment:
- Wear clothing to limit skin contact, i.e., aprons, coveralls, long sleeve shirts, etc.
- Exposure Guidelines
- OSHA and ACGIH suggest that exposure to any dust or mist be kept below the level of a nuisance particulate. For particulates not otherwise regulated, the OSHA PEL for the respirable fraction is 5 mg/m³ and for total dust the OSHA PEL is 15 mg/m³. The ACGIH threshold limit value for particulates not otherwise classified (PNOC) is 10 mg/m³ for an 8-hour TWA. OSHA PEL and ACGIH TLV for phosphoric acid is 1 mg/m³ for an 8-hour TWA and 3 mg/m³ for a 15-minute STEL.
-

NUCHAR WV-B ACTIVATED CARBON

Page 4 of 6

Revision Date: 2/17/95Revision No.: 2**9. PHYSICAL AND CHEMICAL PROPERTIES (TYPICAL)**

Boiling Point, °C:	4000	Apparent Density, lbs/ft ³ :	14 - 19
Melting Point, °C:	3500	Solubility in Water:	Insoluble
Freezing Point, °C:	Not applicable	Water Solubles, % max:	4.0
Vapor Pressure, mm Hg:	Not applicable	Physical State:	Solid
Surface Area (Nitrogen BET Method), m ² /g:	1400 - 1600	Appearance:	Black granules
Total Pore Volume, cm ³ /g:	2.2 - 2.5	Odor:	Odorless

10. STABILITY AND REACTIVITY

Chemical Stability:	• Stable
Conditions to Avoid:	• Heat and ignition sources, strong oxidizers, and combustible materials
Hazardous Decomposition Products:	• CO, CO ₂ , P ₂ O ₅
Hazardous Polymerization:	• None

11. TOXICOLOGICAL INFORMATION

Eyes:	• Irritant
Skin:	• Not a primary skin irritant, sensitizing, or corrosive agent
Inhalation:	• Not established
Ingestion:	• Oral LD ₅₀ > 5g/kg (rats)
Subchronic Effects:	• Not established
Teratology (Birth Defects):	• Not established
Mutagenicity (Genetic Effects):	• Not established

12. ECOLOGICAL INFORMATION

Ecotoxicological Information:	
• LC ₅₀ (minnows):	Not established
• Effect of low concentrations on aquatic life is unknown.	
Chemical Fate Information:	Not established

NUCHAR WV-B ACTIVATED CARBON

Page 5 of 6

Revision Date: 2/17/95Revision No.: 2**13. DISPOSAL CONSIDERATIONS**

Activated Carbon is not classified as a hazardous waste. Follow federal, state, and local regulations for industrial waste disposal. Incineration or landfilling in permitted facilities is recommended.

14. TRANSPORT INFORMATION

DOT Description:
 Proper Shipping Name:
 Hazard Class:

- Carbon, activated
- Nuchar Activated Carbon was tested according to the IMDG Code "Self-Heating Test for Carbon" and is not considered spontaneously combustible. Therefore, Nuchar Activated Carbon is not subject to the provisions contained in the IMDG Code for "Carbon, activated."

UN/NA Number:

- Not applicable

15. REGULATORY INFORMATION

U.S. Federal Regulations:

OSHA (29 CFR 1910.1200):
 CERCLA (40 CFR 302.4):

- Air contaminant, Table Z-1-A
- Phosphoric acid is listed as a CERCLA hazardous substance, RQ=5000 lbs

RCRA (40 CFR 261.33, 261.20-24):

- Listed Hazardous Waste: No
- Exhibits characteristics of hazardous waste: No

SARA Section 312 (40 CFR 355)
 Hazard Category:

- Physical Hazards: None known
- Health Hazards: Eye irritant

SARA Section 313:

- This product contains phosphoric acid which is subject to the reporting requirements of SARA Title III, Section 313.

Toxic Substance Control Act:

- Listed in the TSCA inventory of chemicals, 7440-44-0.

State Right to Know Acts (MA, NJ, PA):

- Component subject to reporting is:
 Phosphoric acid ≤ 10%

California Proposition 65:

- The required chemical analyses and risks assessments were performed on this product. Results indicate that there are no significant risks (or observable effects) as defined by this statute, associated with this product under conditions of normal use.

International Regulations:

Canada (DSL):
 Canada (NPRI):

- Listed in inventory: 7440-44-0
- This product contains phosphoric acid which is subject to the reporting requirements of NPRI.

Canada (WHMIS):
 Europe (EINECS):
 Japan (MITI):
 Australia (AICS):

- Activated carbon is regulated under WHMIS
- Listed in inventory: 2311533
- Not applicable
- Listed in inventory: 7440-44-0

FCC:

- Nuchar activated carbon meets all specifications set forth in the 1981 edition and later supplements of the Food Chemicals Codex.

RECEIVED AUG 08 1995

NUCHAR WV-B ACTIVATED CARBON

Page 6 of 6

Revision Date: 2/17/95

Revision No.: 2

16. OTHER INFORMATION

Hazard Rating:

HMIS:

- Health - 1
- Flammability - 1
- Reactivity - 0
- Protective Equipment - To be set by user

Revision Summary: • Add FCC statement and correct composition

Supersedes: • 5/18/94

ABBREVIATIONS

1. ACGIH American Conference of Governmental Industrial Hygienists
2. BOD_x Biochemical Oxygen Demand (After x Days)
3. CERCLA Comprehensive Environmental Response, Compensation, and Liability Act of 1980 (CERCLA)
4. CFR Code of Federal Regulations
5. COD Chemical Oxygen Demand
6. cps Centipoise
7. DOT Department of Transportation
8. EPA Environmental Protection Agency
9. HMIS Hazardous Material Information System
10. IARC International Agency for Research on Cancer
11. LC₅₀ A single calculated concentration in air or water resulting in 50% mortality of a group of test animals.
12. LD₅₀ A single calculated dose of a material expected to kill 50% of a group of test animals.
13. LEL Lower Explosive Limit in air
14. MSHA Mine Safety and Health Administration
15. NIOSH National Institute for Occupational Safety and Health
16. NTP National Toxicology Programs
17. OSHA Occupational Safety and Health Administration
18. PEL Permissible Exposure Limit established by OSHA
19. SARA Superfund Amendments and Reauthorization Act
20. TLV Threshold Limit Value
21. TSCA Toxic Substances Control Act
22. TOC Total Organic Carbon
23. UEL Upper Explosive Limit in air