

**" Save
Your
Breath
With **NST**[®]
MODERN SAFETY TECHNIQUES "**

11370 Breininger Rd. Phone: (800) 542-6646
P.O. Box 87 (888) mod-safe
Hicksville, OH 43526 (419) 542-6645
Email: sales@modsafe.com Fax: (419) 542-6475
www.modsafe.com

**MST ELECTRONIC FILTER LIFE TIMER
FOR
8022801 ASSEMBLY
8022802 ASSEMBLY**

NOTE: FIELD INSTALLATION INSTRUCTIONS INCLUDED.

05/2016

MST ELECTRONIC FILTER LIFE TIMER FOR 8022801/8022802 ASSEMBLIES

The MST Electronic Filter Life Timer is designed to monitor your replacement filter element frequency in your MST Breathing Air Purification System. When pressure to MST Breathing Air Filter/Purification System reaches 40 PSIG or greater the timer will start; the timer will stop timing below this pressure.

The MST Electronic Filter Life Timer consists of a miniature pressure switch connected to a continuous reading digital timer. The timer will continuously count to 99999-99 (hours - hundredths) at which time, the display will return to zeros. The timer contains a non-replaceable lithium battery.

CAUTION : WHEN THE FILTRATION SYSTEM IS NOT IN USE, BE SURE TO SHUT OFF THE AIR SUPPLY TO THE SYSTEM SO NOT TO PRODUCE FALSE READINGS REGARDING ACTUAL FILTER USAGE.

GENERAL SPECIFICATIONS

STANDARD ON/OFF PRESSURE SETTING 40 PSIG

POWER REQUIREMENTS NON-REPLACEABLE
LITHIUM BATTERY

OPERATING TEMPERATURE 15 to 130^o F
(-10 to 55^o C)

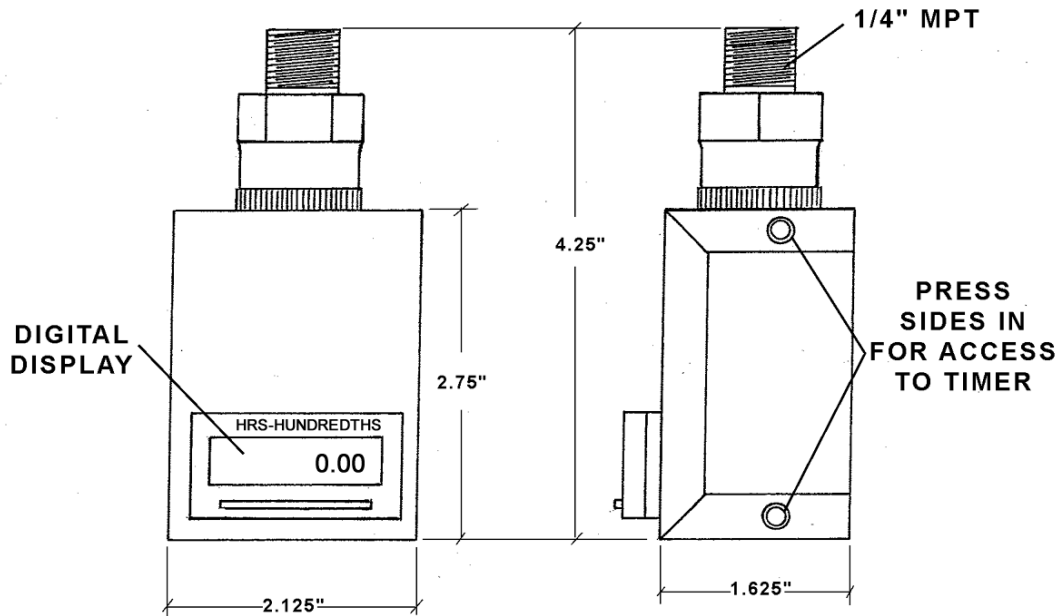

MST ELECTRONIC FILTER LIFE TIMER FOR 8022801 ASSEMBLY

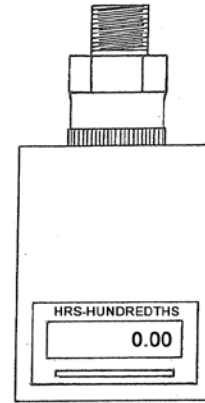
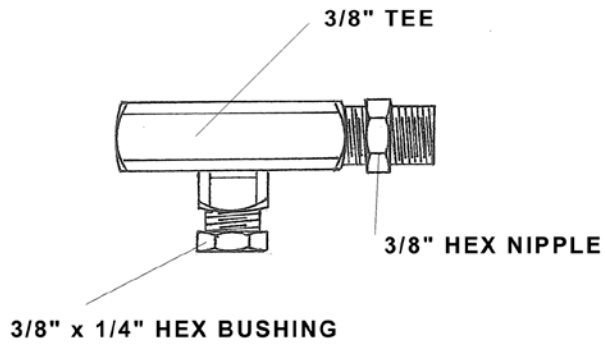

MST ELECTRONIC
FILTER LIFE TIMER

MST ELECTRONIC FILTER LIFE TIMER FOR 8022802 ASSEMBLY

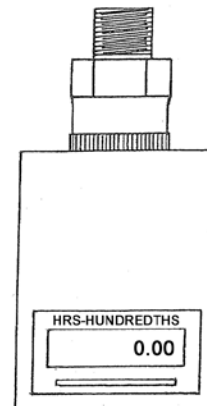
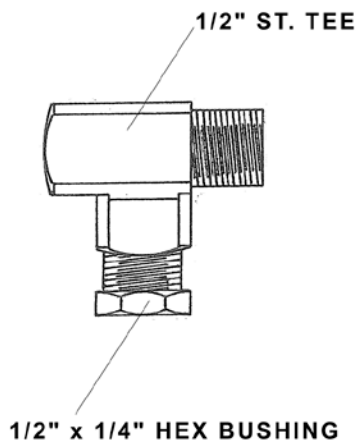

MST ELECTRONIC
FILTER LIFE TIMER

MST ELECTRONIC FILTER LIFE TIMER FIELD INSTALLATION FOR 8022801 AND 8022802 ASSEMBLIES

- 1) Remove the 'CO' Monitor (detach the clear sample tube from the flowmeter's locking collar).

Remove the black plastic tubing (A) from the two 90 Legris Elbows (B) by pulling back on locking collar of the Legris Elbow and pulling black tubing out. Now remove the top 90 Legris Elbow (B) from the Filter Manifold (C).

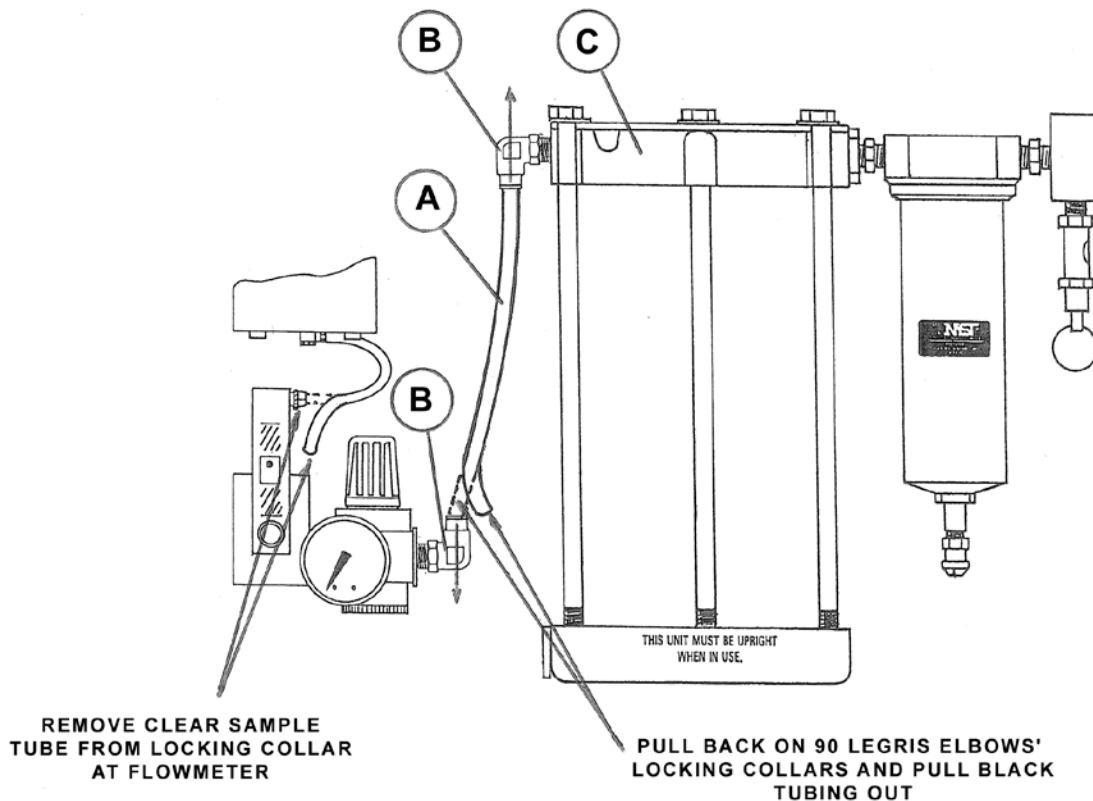

8022801 / 8022802 FIELD INSTALLATION CONTINUED

- 2) Re-tape the threads of the 90 Legris Elbow that was removed and install in the Filter Life Timer Tee Assembly **(D)**.

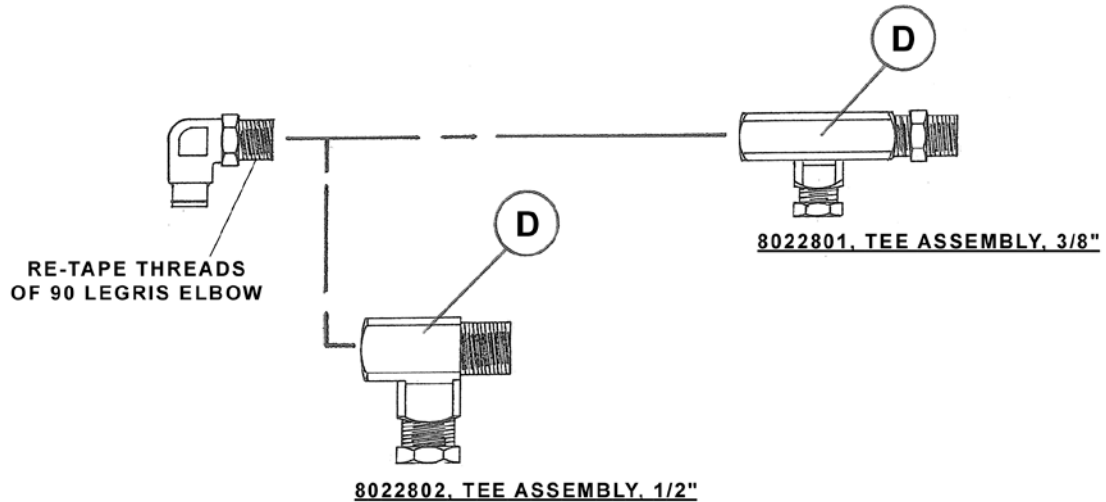

- 3) Install the Tee Assembly **(D)** into the Filter Manifold **(C)** and then install the Filter Life Timer **(E)** into the Tee Assembly. Be sure to use the machined hex on the Filter Life Timer **(E)** to tighten into the tee's leg (damage may occur if tightened otherwise).

8022801 / 8022802 FIELD INSTALLATION CONTINUED

- 4) Now install the new 12" long black tubing (F) into the (2) 90 Legris Elbows. Install one end of black tubing into the top 90 Legris Elbow by pushing upward. Pull down on black tubing, making sure it is locked into the 90 Legris Elbow. Do the same on other end of black tubing/90 Legris Elbow. Finally, re-install the 'CO' Monitor in the case and install the air sample tube back into the flowmeter's locking collar.

