

**" Save
Your
Breath
With **INST**®
MODERN SAFETY TECHNIQUES "**

11370 Breininger Rd. Phone: (800) 542-6646
P.O. Box 87 (888) mod-safe
Hicksville, OH 43526 (419) 542-6645
Email: sales@modsafe.com Fax: (419) 542-6475
www.modsafe.com

**MODEL RP050BMST
"TRUE BLUE™"
RESPIRATORY PROTECTOR®
MANUAL**

WARNING: Do not attempt to operate this equipment without first reading and understanding the manual enclosed with this device. Suitability for use of this device lies solely with user.

CONTENTS

SPECIFICATIONS	3
GENERAL SAFETY WARNINGS	4
GENERAL FILTER SYSTEM DESCRIPTION	5
GENERAL OPERATIONS	
INTRODUCTION	6
CUSTOMER AIR SUPPLY	6
MST RESPIRATORY PROTECTOR INITIAL INSTALLATION AND START-UP	7
MST RESPIRATORY PROTECTOR GENERAL OPERATION AND MAINTENANCE	10
FILTER SET SERVICE INSTRUCTIONS	11
RECORD KEEPING	13
PERFORMANCE CURVES	15
PART LIST	17

SPECIFICATIONS
RESPIRATORY PROTECTOR®
MODEL RP050BMST

INLET PRESSURE (MAX.)	150 PSIG STATIC (10.4bar)
RATED AIR FLOW (MAX.)	50 SCFM (23.6 L/s)
OPERATING PRESSURE	100 PSIG DYNAMIC (6.9bar)
OUTLET PRESSURE RANGE	0-125 PSIG (0-8.6 bar)
OPERATING RELATIVE HUMIDITY (INLET AIR)	30-100% RH
OPERATING TEMPERATURE RANGE (INLET AIR)	68-150°F (20-65°C)
INLET CARBON MONOXIDE CONCENTRATION (MAX.)	40 PPM (VOLUME)*
OUTSIDE DIMENSIONS	23.25"L x 20.75"W x 9"D (590mm x 527mm x 229mm)
WEIGHT (INCLUDING MONITOR)	31 LBS. (14.1 kg.)
REPLACEMENT FILTER SET	FX050

***BASED ON MAXIMUM FLOW CONDITIONS (50 SCFM) FOR 40 HOURS MINIMUM CONTINUOUS PERFORMANCE.**

GENERAL SAFETY WARNINGS

WARNING: The MST RESPIRATORY PROTECTOR MODELS:

- 1) SHOULD NOT be used when the air entering the filtering system is oxygen deficient. The MST Respiratory Protector[®] will not increase the oxygen content of the air.
- 2) SHOULD NOT be used in an Immediately Dangerous to Life and Health Atmosphere (IDLH) unless it is used in conjunction with a Back-Up Escape system or a supplied air Self-Contained Breathing Apparatus (SCBA), where applicable.
- 3) CARBON MONOXIDE MONITOR will alarm if Carbon Monoxide levels exceed requirements for Grade "D" Breathing Air set fourth by OSHA/CSA. If alarm should sound, remove respirator or activate SCBA and immediately move to safe breathable atmosphere. Have the proper qualified personnel examine the equipment and make the appropriate corrections before using again.
- 4) SHOULD NOT have air inlet pressure greater than 150 PSIG static (10.4bar). Personal injury could result.
- 5) SHOULD NOT have air outlet pressure that exceeds Manufacturers' Respirator/Hose Assembly pressure requirements. Personal injury could result.

The MST Respiratory Protector[®] is a Four Stage Purification System designed to remove or reduce select contaminates including Carbon Monoxide that is found in compressed air lines while monitoring for carbon monoxide through the MST Monitor. The Respiratory Protector can be connected directly to shop air from a standard compressed air source to help provide breathing quality air to face masks, helmets, hoods and other supplied air breathing apparatus.

GENERAL FILTER SYSTEM DESCRIPTION

(Refer to Figure No.1)

Air entering the MST Respiratory Protector[®] at the inlet **(A)** is usually contaminated with oil, water, dirt, rust, scale, gaseous Hydrocarbons and often deadly Carbon Monoxide. As the air passes through the First Stage **(B)** of the MST Prefilter, solid particulate matter of three (3) micron and larger are trapped by a high surface area pleated filter media. The air then passes through the Second Stage **(C)** of the Prefilter which traps all particulate matter larger than 0.3 micron and coalesces liquid aerosols with an efficiency rating of 99.97% (D.O.P. 0.3-0.6 micron). MST's Prefilter meets Underwriters Laboratory Specification UL586 for High Efficiency, Particulate, Air Filter Units. The liquid contaminates are trapped in the lower chamber of the prefilter and expelled out through the Automatic Float Drain **(D)**. The Third Stage **(E)** contains a deep bed of odor absorbing activated charcoal which collects various gaseous Hydrocarbons (such as oil vapors, benzene, etc.). The Fourth Stage **(F)** contains a low temperature catalyst which converts Carbon Monoxide gas into Carbon Dioxide. The unique catalyst also converts or absorbs ozone, Nitric Oxide, Sulfur Dioxide, Nitrogen Dioxide, Hydrogen Sulfide, Ammonia, Acetaldehyde, Methyl Chloride, Methyl Ethyl Ketone, Acetone and Methyl Alcohol. The air then passes through a one (1) micron filter disc **(G)** before entering the Regulator **(H)**, which is used to adjust the air pressure going to the respirator(s). A sample of the filtered air is taken at **(I)** and passed through the Carbon Monoxide Monitor **(J)**. The Carbon Monoxide Monitor continuously checks the carbon monoxide levels per OSHA/CSA requirements and digitally displays the amount present in PPM, (parts per million). An audio and visual alarm will alert operators if levels of carbon monoxide exceed OSHA/CSA requirements.

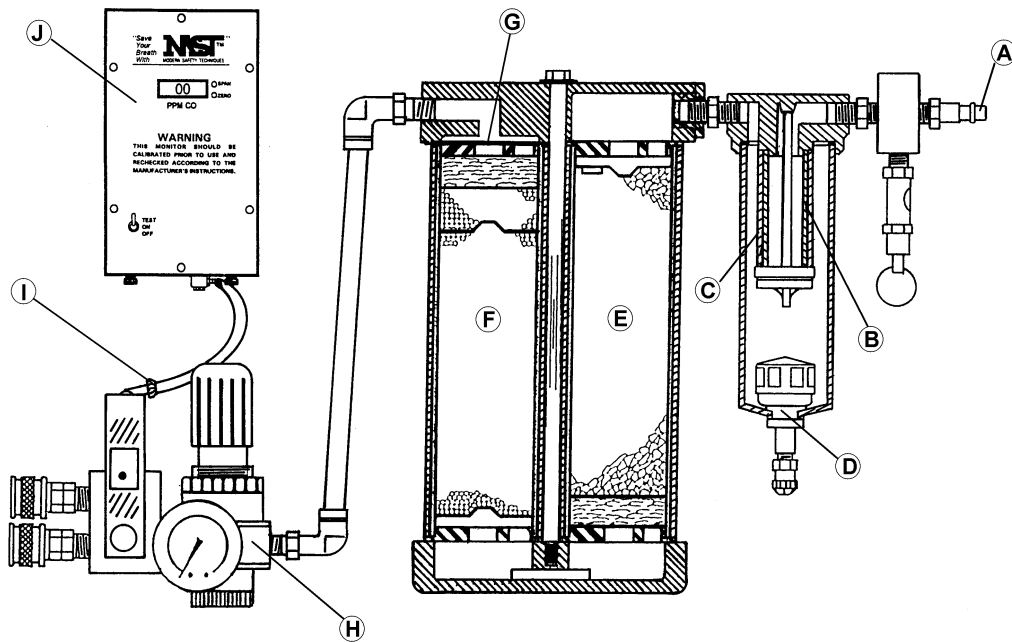

GENERAL OPERATIONS

WARNING: The MST Respiratory Protector should not:

1) be used when the air entering MST's Unit is oxygen deficient. MST's Unit will not increase the oxygen content of the oxygen deficient air.

2) be used in an "Immediately Dangerous to Life and Health" atmosphere, (IDLH), unless it is used in conjunction with a back-up escape system or a supplied air self-contained breathing apparatus, (SCBA), where applicable.

MST, Inc. strongly recommends that a complete safety program be instated to ensure that the respiratory air is in compliance with all OSHA/CSA standards and other applicable laws regulating the use of supplied air respiratory systems. MST, Inc. recommends that the air quality be tested upon installation and periodically re-tested to ensure that the minimum requirements for breathing air are maintained.

MST, Inc. will not assume any liability for accidents or personal injury resulting from the improper use of this equipment. Service on this equipment should only be performed by qualified personnel. This system is to be used only by trained qualified personnel in accordance with a respiratory program as outlined in OSHA Regulation 29 CFR 1910.134(b).

CUSTOMER AIR SUPPLY

(Refer To Figure No. 2)

- 1) SUPPLIED AIR LINE - Use minimum 3/8" I.D. hose or pipe to MST Unit.
- 2) SUPPLIED AIR LINE PRESSURE - Maximum air pressure at MST Unit's inlet should not exceed 150 PSIG. As a Safety Back-Up, all MST Units incorporate a pressure relief valve rated at 150 PSIG.
- 3) SUPPLIED INLET AIR TEMPERATURE RANGE - 68 to 150°F (20-65°C).
- 4) SUPPLIED AIR CONDITIONING - May be required ahead of MST's Unit to control:
 - a) Inlet air temperature.
 - b) Large Volumes of oil/water from entering MST Unit. A coarse oil/water extractor, (rated at 2-microns abs.), may be required if excessive oil/water conditions are present. Installation of the extractor should be located as close to MST Unit's inlet hook-up as possible. MST, Inc. has coarse oil/water extractors available as an option.
- 5) AVOID INSTALLING MST UNIT AFTER DESICCANT DRYER - The Desiccant Dryer will produce extremely dry air, (4% R.H. or less), and MST's fourth stage catalyst requires 30-90% R.H. in the supplied air for the catalyst to work and remove Carbon Monoxide efficiently. The extremely dry air produced by a Desiccant Dryer will also cause worker discomfort, i.e. dry throat, etc.

MST RESPIRATORY PROTECTOR INITIAL INSTALLATION AND START-UP

(Refer To Figure No. 2)

- 1) **INSTALL AIR FITTINGS SUPPLIED WITH MST UNIT** - Industrial Interchange air fittings supplied standard with unit, Schrader Quick-Disconnect fittings available as option.
- 2) **NEW FILTER SYSTEM CONDITIONING** - Flow supplied air through new filter sets for several minutes to condition.
- 3) **POWER MONITOR/CALIBRATE** - Install the (2) 9-volt batteries and/or optional power source to the MST monitor and switch monitor on for minimum (5) minute warm-up. After warm-up period, check monitor's circuits/audible-visual alarm system by pressing "Off/On/Test" switch up and hold. If monitor OK, the following will occur:
 - a) Red/Amber LED - will come on steady
 - b) Green LED - will blink initially and then come on solid.
 - c) Audible alarm will sound and the remote alarm jack will be energized.

Monitor's calibration should be checked now. Refer to MST MONITOR MANUAL.

- 4) **CALIBRATION GAS REQUIREMENTS** - Zero Gas: Nitrogen, free of "CO". Span Gas: 50 to 150 PPM of "CO" concentration in air. Calibration gas flow to monitor should be 1.0 SCFH (472 cc/minute).
- 5) **RESPIRATOR/HOOD/HOSE ASSEMBLY HOOK-UP** - Couple hose assemblies to MST Unit's outlet using appropriate fittings. Consult Manufacturer's respirator manual for the proper air pressure requirements. The air should be dynamically flowing through respirator/hose assemblies when the air pressure is set. **DO NOT EXCEED RESPIRATOR/HOSE ASSEMBLY MANUFACTURER'S REQUIREMENTS FOR OUTLET PRESSURE. PERSONAL INJURY COULD RESULT.**
- 6) After pressurizing system and setting regulator for proper air flow to respirator(s), adjust air sample metering valve's adjustment knob so the black floating ball is within the GREEN boxed area etched on valve body.
- 7) **EXTREME TEMPERATURE CHANGES** - Avoid; MST monitor best performs at a temperature range of 32-104°F (0-40°C). Always calibrate monitor after it has stabilized in the surrounding temperature where system is to be used.

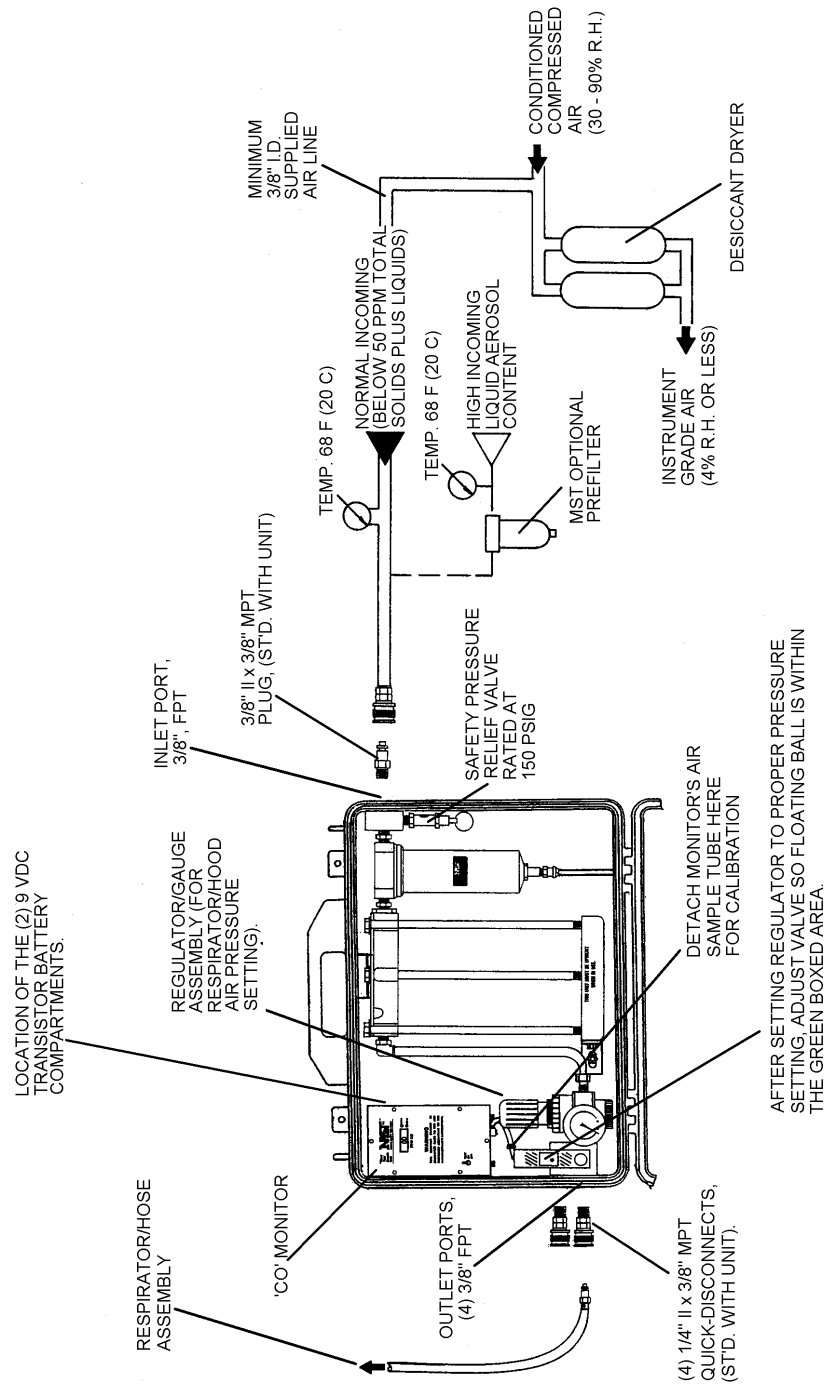

Figure No. 2

AIR SAMPLE MONITOR ADJUSTMENT

WARNING: SERIOUS INJURY could result if the **AIR SAMPLE METERING VALVE** is not properly adjusted. Proper sample air flow to 'CO' monitor is required for monitor to give correct 'CO' level readout.

AIR SAMPLE METERING VALVE ADJUSTMENT

- A) Pressurize system and set regulator for proper air flow to respirator(s).
- B) Adjust Air Sample Metering Valve's adjustment knob so the black floating ball is within the GREEN BOXED area etched on valve body. Proper air sample is now being metered to the 'CO' Monitor. Periodically check to be sure ball is floating in this area.

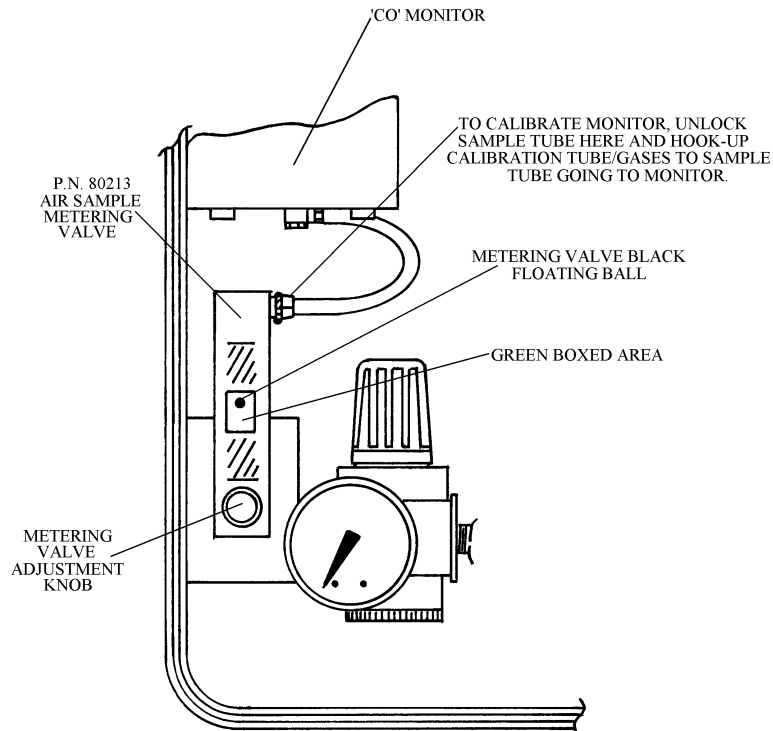

MST RESPIRATORY PROTECTOR® GENERAL OPERATION AND MAINTENANCE

- 1) MST MONITOR - Utilizes an electrochemical sensor to measure the carbon monoxide content of the respirable air. If a problem has developed in the system, the monitor will alarm due to one or more of the following conditions:
 - a) Monitor is out of calibration. The monitor should be calibrated monthly if used continuously and prior to use if used on a non-continuous basis. Calibrate monitor as outlined in the MST MONITOR MANUAL.
 - b) If the monitor can be and is calibrated, but the alarm still sounds, the filter cartridge life is exhausted. Replace all three (3) filter cartridges as outlined in the FILTERREPLACEMENT INSTRUCTIONS, page 9.
 - c) If the monitor cannot be calibrated, the carbon monoxide sensor may require replacement. See MST MONITOR MANUAL for replacement instructions and other troubleshooting information. The MST MONITOR has one (1) year warranty. All warranty work must be performed at factory.
 - d) If the monitor was calibrated in a surrounding temperature other than where the system was being used and the temperature difference was 36°F (20°C) or greater, the monitor may give a false alarm due to its characteristics. Always calibrate the monitor in the temperature conditions where the monitor is to be used in. Monitor best performs at temperature range of 32 to 104°F (0 to 40°C).
- 2) MST MONITOR - Alarms should be checked prior to use.
- 3) MST MONITOR - Power supply is (2) 9-volt transistor - type batteries, (unless optional power supply used). The batteries will power the monitor continuously for approximately (30-35) hours. When the batteries output fall below (7.0) volts, the Amber LED "Low Battery" light will come on, indicating the batteries require replacement. When installing the new batteries into the battery holders, review polarity position marked inside holders and install batteries accordingly.
- 4) MST MONITOR - Flow of the air sample to monitor should be checked periodically. Check periodically that the black floating ball is within the GREEN BOXED area etched on the valve body when air is flowing to respirators.
- 5) MST RESPIRATORY PROTECTOR® SYSTEM - Filters should be replaced monthly unless the air quality conditions warrant more or less frequent replacement. Replace all (3) filter cartridges if:
 - a) The "CO" monitor alarms (fourth stage catalyst is used up).
 - b) The operator detects a petroleum smell and or taste in his purified air (third stage charcoal is used up).

NOTE: If the supplied air entering MST's unit has high volumes of liquids in it, the filter set life may be greatly reduced. See CUSTOMER AIR SUPPLY, page 6, for corrective measures to take.

- 6) MST RESPIRATORY PROTECTOR® SYSTEM - New filter set:
 - a) Has an indefinite shelf life, but should be stored in a cool/dry storage area.
 - b) When first installed in MST's unit the filters should be conditioned by flowing the customer's supplied air through system for several minutes.

NOTE: If MST's unit is not to be used for an extended period of time, before storing, check 3rd and 4th stage filters for presence of liquid/moisture. If moisture present, dry system and replace all filters. Also, if moisture present, consider changing filter set more frequent and or installing MST's OPTIONAL PREFILTER prior to MST's system hook-up.

FILTER SET **SERVICE INSTRUCTIONS**

(Refer To Figure No. 3)

WARNING: Always turn off air supply and bleed air pressure before disassembling unit or SERIOUS INJURY COULD RESULT.

MST, Inc. recommends replacing all three (3) filter cartridges after one (1) month of use unless conditions warrant more or less frequent replacement. To replace the filter cartridges in the RESPIRATORY PROTECTOR® follow these steps:

- 1) PREFILTER FIRST/SECOND DUAL STAGE ELEMENT REPLACEMENT
 - a) First unlock tube locking collar and then pull Drain Tube **(1)** down through case. Then unscrew Prefilter Bowl Assembly **(2)** , clean in mild soap and water and blow dry with low pressure air.
 - b) Remove Dual Stage Element **(3)** by unscrewing End Cap Retaining Nut **(4)** .
 - c) Inspect the Prefilter Manifold **(5)** for dirt/contaminates and clean as required. Inspect O-Ring **(6)** for cuts, etc. and replace if required.
 - d) Install new Dual Stage Element and Tighten End Cap Retaining Nut. Be sure Element is seated squarely on Manifold boss and End Cap.
 - e) Apply light film of petroleum jelly on Bowl's beveled edge to provide good seal between Bowl and O-Ring. HAND TIGHTEN ONLY.
 - f) Guide Drain Tube back through hole in case bottom and lock into tube locking collar.
 - g) Dispose of used Dual Stage Element according to local, state and federal regulations.
- 2) THIRD/FOURTH STAGE CARTRIDGE REPLACEMENT
 - a) Loosen Bracket Bolt **(7)** from Bracket **(8)**, (do not remove).
 - b) Loosen the five Manifold Bolts **(9)** and remove the front two Bolts. Now slide out the Third **(10)** and Fourth **(11)** Stage Aluminum Tube Assemblies.
 - c) Remove the End Cap **(12)** from Third Stage Aluminum Tube Assembly and slide old Third Stage Filter Cartridge **(13)** out of aluminum tube. Clean aluminum tube in mild soap and water, dry and install new Third Stage Filter

- Cartridge. Be sure the Flow Direction Arrow on Third Stage Filter Cartridge is pointing down. Remove End Sealing Label (14) and install new End Cap.
- d) Follow same procedure for the Fourth Stage Filter Cartridge (15) replacement as in step (C). Be sure the Flow Direction Arrow on Fourth Stage Filter Cartridge is pointing up. Also be sure to remove End Sealing Label before installing new End Cap.
 - e) Now slide the Third and Fourth Stage Aluminum Tube Assemblies back in place and install the front two Manifold Bolts.
 - f) Tighten Manifold Bolts in sequence from center outward to 100 inch-pounds (1.15 Kg-M). Repeat sequence and re-torque bolts to 250 inch-pounds (2.88 Kg-M).
 - g) Tighten Bracket Bolt (7) against Bracket (8) .
 - h) Dispose of used cartridges according to local, state and federal regulations.

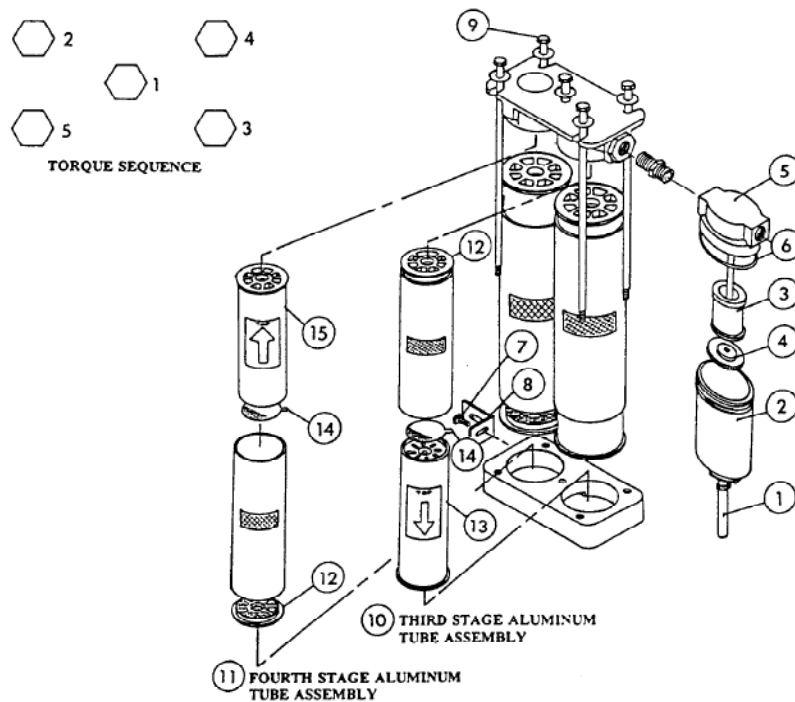

Figure No. 3

3) FINAL CHECK AND CALIBRATION

- a) Pressurize system and check for leaks.
- b) Flush system with compressed air for several minutes.
- c) Calibrate Carbon Monoxide Monitor as outlined in MST MONITOR MANUAL.

RECORD KEEPING

Record all periodical air quality checks, monitor calibration date, filter cartridge change intervals and any other service performed on the MST RESPIRATORY PROTECTOR®

MST INC. SHALL NOT BE LIABLE FOR ANY INJURY, LOSS OR DAMAGE, (DIRECT OR CONSEQUENTIAL), ARISING OUT OF THE USE OF OR THE INABILITY TO USE THIS PRODUCT, BEYOND THE REPLACEMENT OF DEFECTIVE MATERIALS OR WORKMANSHIP. USER OF SUPPLIED AIR RESPIRATORS SHOULD EVALUATE THEIR OWN PARTICULAR APPLICATION AND PERFORM THEIR OWN TESTS FOR AIR QUALITY TO DETERMINE THE SUITABILITY FOR USE OF THIS PRODUCT.

For further information, or questions about service or maintenance care of this unit, contact your local distributor or MST, Inc. at (800) 542-6646.

MST, INC.
SERVICE RECORD
RESPIRATORY PROTECTOR®
MODEL RP050BMST

DATE OF SERVICE	SERVICE PERFORMED

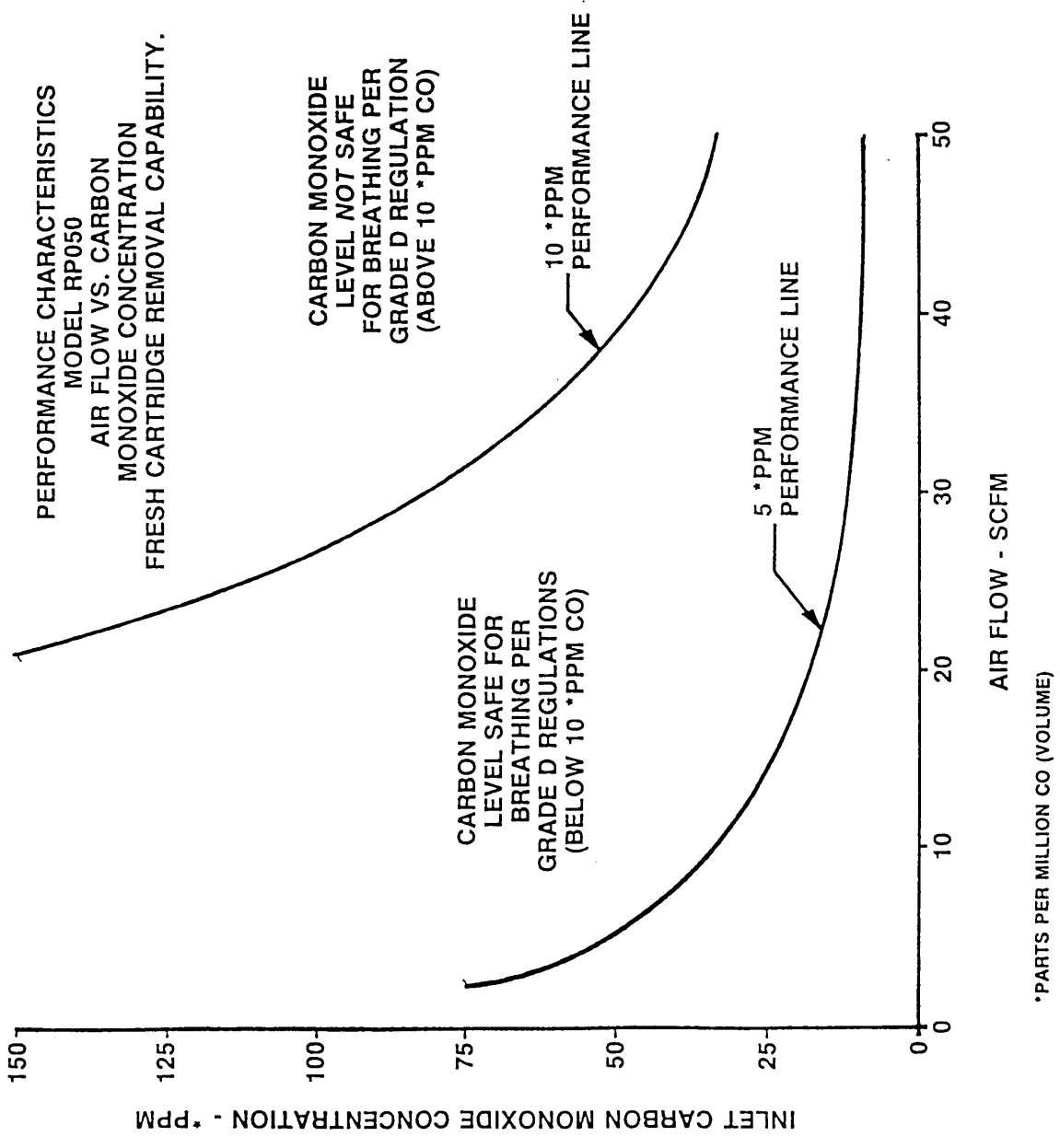

PERFORMANCE CHARACTERISTICS
MODEL RP050
AIR FLOW VS. PRESSURE DROP

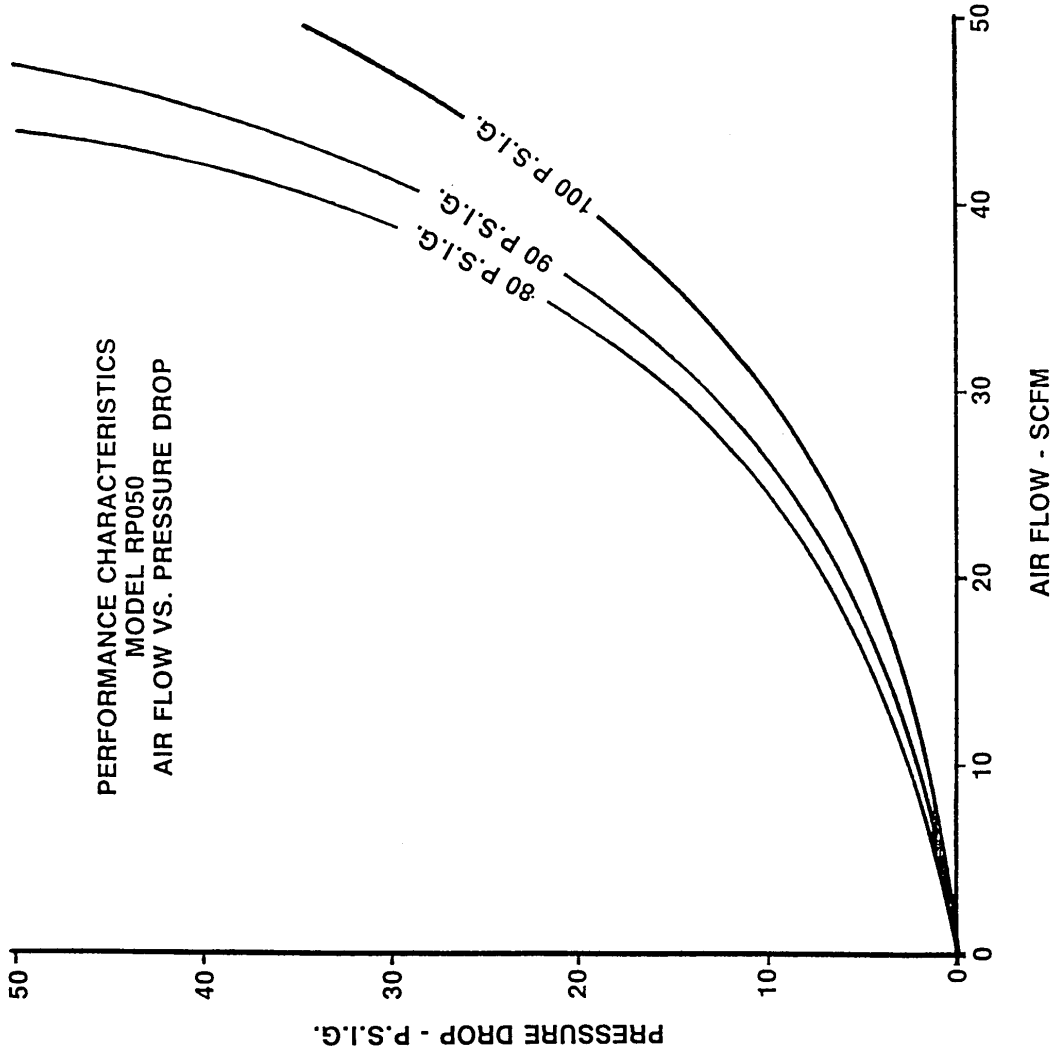

RESPIRATORY PROTECTOR® MODEL RP050BMST PARTS

- | | | | |
|----|-----------------------------------|----|-------------------------------------|
| 1 | 80025, (1), Blue Case | 14 | 80009, (1), Manifold Bracket |
| 2 | 80008, (1), Black Porting Block | 15 | S006-148, (3), Bracket Bolts |
| 3 | 80014, (1), Pressure Relief Valve | 16 | S011-040, (5), Manifold Bolts |
| 4 | S608-005, (3), Hex Nipple - 3/8" | 17 | 12021, (5), Manifold Washers |
| 5 | 80090, (1), Prefilter-50 SCFM | 18 | 80116, (2), Tubing St. Elbow |
| 6 | 80051, (1), Tube Locking Collar | 19 | 80117-B, (1) Tubing |
| 7 | S710-005, (1) Drain Tube | 20 | 80080, (1) Regulator |
| 8 | 80001, (1), Black Base | 21 | 80047, (1), Black Outlet Block |
| 9 | 80005, (1), AI Tube Third Stage | 22 | S687-001, (3), 1/8" Hex Pipe Plug |
| 10 | 80005, (1), AI Tube Fourth Stage | 23 | S603-001, (1), Close Nipple, 1/8" |
| 11 | 80114, (1), Base Bracket | 24 | 80213, (1), Sampling Metering Valve |
| 12 | 80078, (1), Black Manifold | 25 | 80261, (1), Sampling Hose Connector |
| 13 | 80127, (1), MST "CO" Monitor | 26 | 80076, (1), Pressure Gauge, 0-160 |

